

Ultrasonic Tank Level Monitoring System

Tank sizes 6,000 to 90,000 gallons (22,712 to 340,686 liters)



Monitor bulk tank levels with industry leading accuracy, so you can optimize your inventory management



Externally Mounted, Install In Minutes

Xact ultrasonic systems mount externally on tanks, allowing for a quick, safe and easy setup. No need to retrofit or decommission tanks.

Dependable, Fail-safe Monitoring

Satellite transmission and ultrasonic accuracy ensure that users will get consistent and accurate fill levels. Avoid the worry of missing data from faulty gauges or failing cell networks.

Other Key Takeaways

- Durable in harsh temperatures ranging from -40°C to 60°C
- No dependence on remote-ready gauges or power sources
- 3-5 year battery operation at 2 readings per day
- Integrates into MIS delivery scheduling programs
- Designed for tank sizes ranging from 6,000 to 90,000 gallons (22,712 to 340,686 liters)

Precise Measurements Within $\pm 2\%$

Xact ultrasonic systems use sound waves to detect fill levels at an accuracy within $\pm 2\%$. These precise measurements help propane marketers get the most out of their inventory and monitor key customer accounts.

Satellite Communication

Xact ultrasonic systems transmit data via the Globalstar® satellite network to our website portal. This allows customers see fill levels online for tanks in areas without reliable cell coverage.





Fail-safe monitoring that you can depend on

LARGE TANK SYSTEM SPECIFICATIONS

Products

- XACT15096 – Transmitter and Com box
- XACT31012 – Transducer

Battery

7.2 volt Lithium Thynol Chloride

Output power of Globalstar Satellite Radio

24dBm ±2 dB

Safety Rating

- Class 1 Division 2 Group D
- Class 1 Zone 2 Group IIA

Strap

Nylon – 40 feet (12 meters)

Transmitter Dimensions (XACT15096)

7.56in L x 5.07in W x 2.67in H
(192mm L x 129mm W x 68mm H)

Com box Dimensions (XACT15096)

4.92in L x 3.15in W x 2.87in H
(125mm L x 80mm W x 73mm H)

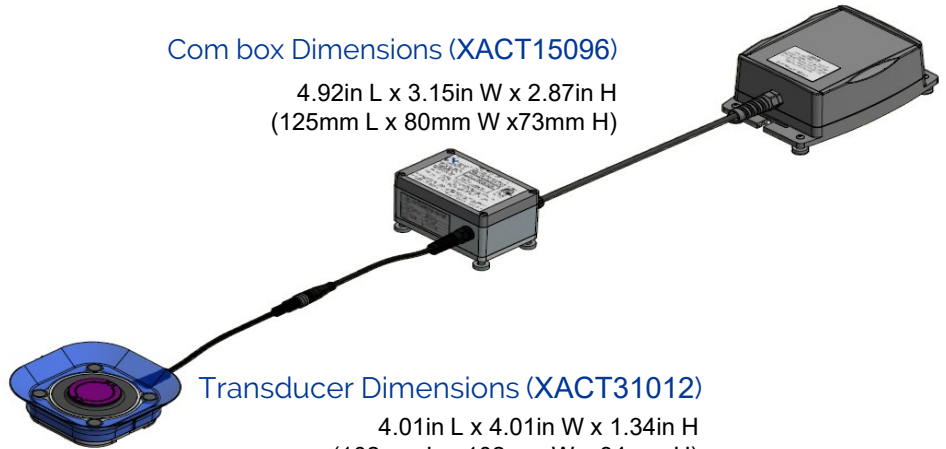

Transducer Dimensions (XACT31012)

4.01in L x 4.01in W x 1.34in H
(102mm L x 102mm W x 34mm H)

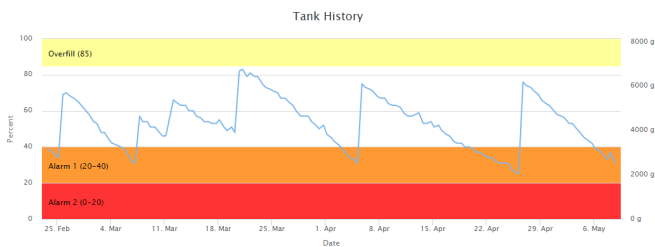

Time (Tank Local)	Temp	Fill Level	Fill Volume	Volume Change	Ullage	Battery
May 8, 2019 6:25 PM	51.8°F	31%	2,540 gallons	-450 gallons	3,981 gallons	6.91V
May 8, 2019 4:15 AM	41.8°F	37%	2,990 gallons	295 gallons	3,531 gallons	6.81V
May 7, 2019 6:20 PM	47.1°F	35%	2,695 gallons	-210 gallons	3,626 gallons	6.87V
May 7, 2019 4:14 AM	37.4°F	36%	2,905 gallons	-195 gallons	3,616 gallons	6.74V
May 6, 2019 6:14 PM	41.1°F	38%	3,100 gallons	-85 gallons	3,421 gallons	6.83V
May 6, 2019 4:14 AM	37.0°F	39%	3,185 gallons	-200 gallons	3,336 gallons	6.74V
May 5, 2019 6:20 PM	37.0°F	42%	3,385 gallons	-285 gallons	3,136 gallons	6.80V

The liquid measurement data, along with the geometry of the tank, are used to calculate the precise fill level ($\pm 2\%$) of the liquid in the tank, which is displayed on the Xact website. The tank fill level can also be integrated into your back-office software, so that you can view all of your data in one place. Other benefits include email alerts of critical tank fill levels, GPS coordinates used for tank location with mapping capabilities and exportation of measurement data. Minimum tank fill level measurement is 10%.

SAFETY LABEL

For more information, visit xact-data.com



Schmitt Industries, Inc.
 Corporate Offices
 2765 NW Nicolai Street
 Portland, Oregon 97210-1818 USA
 Tel: +1 503.227.7908
 Fax: +1 503.223.1258
www.schmitt-ind.com

Model: XACT-01/02 series
 Manf. Date:

Class I, Division 2 Group D
Class I, Zone2 Group IIA

Ex nA nC IIA T6 Gc
 Tamb: -20°C to +55°C

WARNING – EXPLOSION HAZARD – BATTERY MUST ONLY BE CHANGED IN AN AREA KNOWN TO BE NON-HAZARDOUS.
 AVERTISSEMENT – RISQUE D'EXPLOSION – AFIN D'EVITER TOUT RISQUE D'EXPLOSION, S'ASSURER QUE L'EMPLACEMENT EST DESIGNÉ NON GANGEREUX AVANT DE CHANGER LA BATTERIE.

SISTEMA DE MONITOREO PARA TANQUES
 Marca: XACT
 7.2 V (con Baterías)

Gauge Reader Devices - Voc = 7.2VDC, Isc = 0.6A, La = 10.14µH, Ca = 701.26 µF
 Use only replaceable battery pack XEC-722-003

ETL CLASSIFIED
 ETL
 Intertek
 4000718
 NOM-ETL
 Intertek